

UCL PEARL
RIBA Stage 2 [Fire] Report
PRL-BH-01-XX-RP-F-001

18 April 2019

01 Fire

1 Introduction

1.1 Aim

This Stage 2 draft report outlines the key fire strategy requirements for the proposed University College London (UCL) PEARL development.

This Stage 2 Draft report has been produced for consultation with the design team, and Client in order to set out key parameters for the design and operation of the PEARL facility in terms of fire safety. The primary focus for the fire strategy is to demonstrate how the functional life-safety requirements of the Building Regulations 2010 will be met. The information in the following text is related to the architectural drawings produced by Penoyre & Prasad.

1.2 Building Description

The development is a research facility that focuses on accessibility and mobility in life-size environments. It is to be located on the Londoneast-uk development site in Dagenham. The facility will consist of a large warehouse-like space with open plan flexible laboratory area, racked storage areas and a separate two-storey office area. A plant and storage area would also be provided to the East of the building. The total area of the development is approximately 4,670m².

1.3 Applicable Code Guidance

The principal guidance document that the fire strategy will adopt to demonstrate compliance with the functional requirements of Building Regulations 2010, will be BS 9999 'Code of practice for fire safety in the design, management and use of buildings', BSI, 2017.

This guidance allows for a more flexible approach to fire safety design taking into account the occupancy characteristics, fire loading, physical properties (i.e. size and height) and the additional fire safety features that will exist within a development. In these cases fire engineering designs, in accordance with BS 7974 will be used to justify deviations from the code guidance and demonstrate that an equivalent level of safety is provided to a fully code compliant solution.

1.4 Design Basis

The report is based on, and should be read in conjunction with, the proposed plans issued by Penoyre & Prasad on 29/03/2019, as illustrated in Table 1—1. Additional information or variations to the plans referenced may invalidate the conclusions and recommendations contained within the report.

Table 1—1 Documents Referenced

Drawing Number	Description	Rev	Date
PRL-PPA-01-00-DR-A-3200	Ground Floor Plan	P01	27/03/2019
PRL-PPA-01-01-DR-A-3201	First Floor Plan	P01	27/03/2019
PRL-PPA-01-02-DR-A-3202	Second Floor Plan	P01	27/03/2019
PRL-PPA-01-RF-DR-A-3203	Roof Plan	P01	27/03/2019
PRL-PPA-01-SL-DR-A-3110	Proposed Site Plan	P01	27/03/2019
PRL-PPA-01-ZZ-DR-A-3300	Site Sections AA and BB	P01	27/03/2019
PRL-PPA-01-ZZ-DR-A-3310	GA Sections 01 and 02	P01	27/03/2019
PRL-PPA-01-ZZ-DR-A-3311	GA Sections 03 and 04	P011	27/03/2019
PRL-PPA-01-ZZ-DR-A-3400	West and East Elevations	P01	27/03/2019
PRL-PPA-01-ZZ-DR-A-3401	East and South Elevations	P01	23/03/2019

01 Fire

1 Introduction

1.5 Fire Safety Management

A significant part of the fire safety regimes within any building is the standard and quality of fire safety management.

This report is not the fire safety management policy and procedures document required as part of the 'responsible person's' statutory compliance with the Regulatory Reform (Fire Safety) Order 2005.

In determining our fire safety design measures, we have clarified our assumptions on the quality of fire safety management to be put in to place by the client to meet statutory requirements.

1.6 Regulatory Reform Order

Responsibility for complying with the Regulatory Reform (Fire Safety) Order rests with the 'responsible person'. In a workplace, this is the employer and any other person who may have control of any part of the premises, e.g. the occupier or owner.

The fire safety strategy developed by the design team is not a risk assessment under the Order but will form part of the information used by the 'responsible person' in developing their risk assessments.

01 Fire

2 Means of Escape

2.1 Evacuation Strategy

The building will follow a simultaneous evacuation strategy, with all occupants evacuating on alarm in any of the building areas.

2.2 Risk Profile

The building does not precisely fit any of the building use groups discussed in BS9999 and the risk profile would need to be determined by carefully analysing the risks.

The experimental set ups in the main Laboratory area could represent a large fire load. The Storage area, which is tall rack storage, would also represent a large fire load and would be open to the Laboratory area, with only a curtain separating them. The potential nature of the fire load is also highly variable. Therefore, this would be classified as an ultra-fast growth rate building (i.e. Category 4). This is a worst case scenario to provide the required flexibility in how the space is used.

In terms of the occupancy, for the majority of time, such as day to day operation and preparation of the experimental set ups, the building would be used by occupants who will be very familiar with the building.

For the experiments, the building would also be used by the experiments participants, who will be unfamiliar with the building. However, the experiments

will likely require high staff presence to manage the experiment proceedings and staff will be trained to assist occupants with evacuation in the event of a fire. Additionally, the Laboratory area has a simple layout, with exits immediately visible to the occupants. Therefore, it is proposed to use "A" classification for the occupancy of the building, i.e. occupants that are both awake and familiar with the building.

This would, however, depend on the training and number of staff proportionate to the number of experiment participants and would need to be discussed with the UCL. Therefore, this would result in the proposed risk profile of A4. This category is unacceptable within the scope of BS 9999, as such this would require the provision of sprinklers within the building, reducing the risk profile to A3.

As the office area is an ancillary area, it is not proposed to fire separate it from the rest of the building and it would also be designed using the same risk profile.

2.3 Experimental Set Ups

At this stage of the project, it is not possible to predict the exact nature and layout of the experiment set ups that would be provided in the facility. As such, separate fire risk assessments (FRA) would need to be conducted where an experiment is likely to affect the fire strategy (such as changes restricting

means of escape, or increasing the assumed fire loading, or increasing the occupant loading beyond that assumed within the fire strategy). This FRA would then be used to determine the escape provisions required and the impact of the proposed test of the fire safety in the building.

For example, it is understood that some of the proposed experiments would involve cold smoke, which would necessitate the disabling of fire and smoke detection within the building. This would require the development of robust management procedures to ensure that safe evacuation is possible.

Within this report we have provided the key fire safety parameters which should be adhered to in terms of means of escape, fire safety systems and fire service access. These parameters can be used as the basis of these focused fire risk assessments.

2.4 Design Occupancy

At this stage, the building will be designed to allow for escape of the assumed occupancy of 600 (500 experiment participants and 100 staff) from the Laboratory area. This assumes that all of the exits from the Laboratory area are suitable for evacuation. This number will need to be confirmed during the discussions with UCL and may need to be adjusted to reflect the desired number of occupants to be present on site.

2.5 Number of Escape Routes

The minimum number of exits from a room, tier, or storey are as per the below table.

Table 2—1 Number of Escape Routes

Maximum Number of Persons	Minimum Number of Escape Routes/ Exits
60	1
600	2
More than 600	3

Where there are more than 60 persons in any location the escape doors should be arranged open in the direction of escape and panic hardware may also be required on any escape routes fitted with a lock, latch or bolt fastenings.

Electronically locked doors and security gates on escape routes should failsafe open on activation of the fire alarm and in the event of a loss of power. Any electronically locked doors on escape routes should be openable through use of Green Break Glass Units located adjacent to the door. All of the escape routes should be kept clear, free of obstacles and maintained available at all times.

01 Fire

2 Means of Escape

2.6 Travel Distances

Based on an A3 risk profile, travel distances in the building should generally be limited to 18m in a single direction of escape and 45m where alternatives are available when taking the fit out of the spaces into account.

Where provided, alternative escape routes should be sited 45 degrees or more apart such that a fire cannot render both routes unavailable at the same time.

2.6.1 Laboratory

The travel distances within the Laboratory area are within the limits described in the section above. The example travel distances are shown in Figure 2–1.

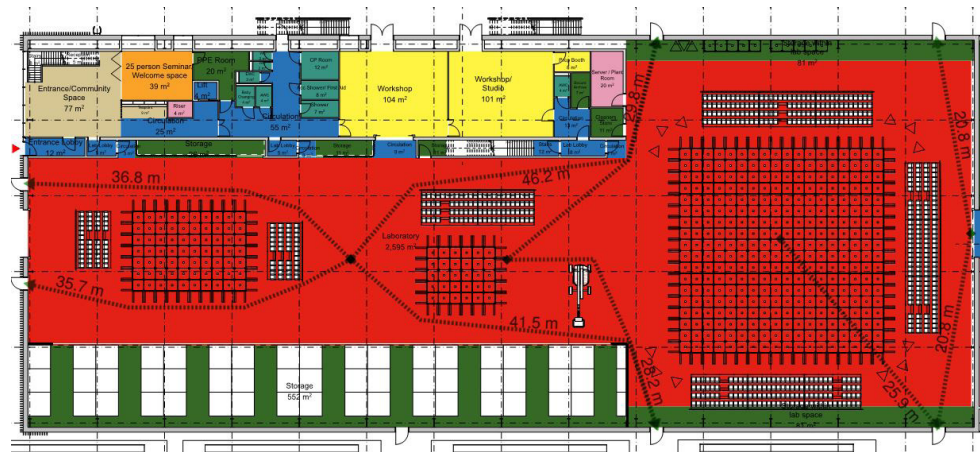

Figure 2–1 Travel Distances in the Laboratory Area

2.6.2 Office

The Office area is located over two levels. Travel distances in the Office are within the recommendations noted in Section 2.6.

The occupants at Ground floor level can escape either directly to outside or to the Laboratory area, from where they can continue their escape via the Laboratory exits.

The occupants at First Floor level of the Office can evacuate via the two external escape staircases (see section 2.8 for additional information on the design of external stairs) and an open accommodation stair leading to the Entrance/Community Space. The use of the open accommodation stair as a secondary escape route from

the Seminar/Briefing room and the adjacent Break out Space is considered reasonable based on the route being a familiar route to the occupants and the travel distances to the final exit at Ground Floor level being within the

recommendations of BS 9999 for travel in multiple directions of escape.

The example travel distances are shown in Figure 2–2 and Figure 2–3.

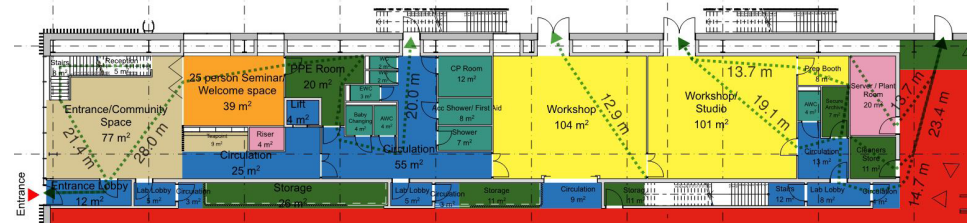

Figure 2–2 Travel Distance in the Office Area – Ground Floor

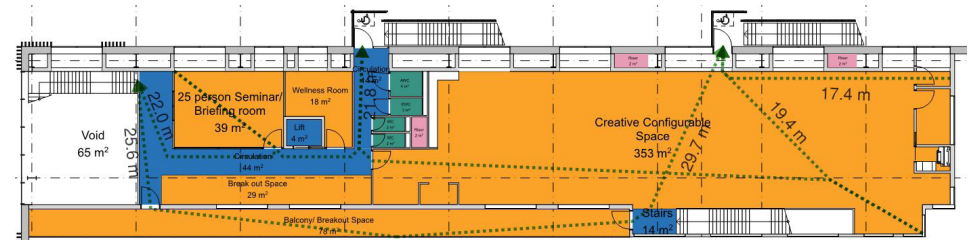

Figure 2–3 Travel Distance in the Office Area – First Floor

01 Fire

2 Means of Escape

After discounting the largest exit, this provides escape capacity for 560 occupants.

Additional escape routes are also available into the Laboratory area, but these are not considered when assessing the escape capacity as Laboratory could represent high fire risk and it is preferred to direct occupants to the exits leading to outside.

2.6.3 Storage

Travel distances from the storage area are within the recommendations of BS9999, as noted in Section 2.6.

2.7 Escape Capacity

2.7.1 Code Guidance

Based on an A3 risk profile, escape capacity from the building should be assessed based on 4.6mm/person for exits 1050mm or larger. Where a door is less than 1050mm wide, including cases where the minimum width has been reduced by the provision of additional fire protection measures, the number of persons safely accommodated by that exit width should be calculated using the following equation:

$$n = 500/m$$

where:

n is the number of persons safely accommodated by the door width;

m is the minimum door width per person, 4.6mm/person

Escape routes should not reduce in effective width required along the route.

Day to day accessibility may have different requirements.

The escape capacity of the doors opening against the direction of escape will be limited to 60 occupants.

2.7.2 Laboratory

Six well-spaced 1,300mm wide exits (clear width) are provided directly to outside from the laboratory area. After discounting one exit, this would provide escape capacity for 1,413 occupants. This is more than sufficient for the expected occupancy of the area.

It is noted the 4 of the exits are via spaces marked as Storage within lab space. As such, management procedures should be developed to ensure that the exits are not obstructed by stored items and are always available for escape.

2.7.3 Office

The escape from the Ground Floor office areas is available directly to outside via the following exits:

- 1,300mm wide (clear width) door to outside from the Circulation area on the North elevation

- 2,300mm wide (clear width) door to outside from Workshop on the North elevation
- 2,300mm wide (clear width) door to outside from Workshop/Studio area on the North elevation

After discounting the largest exit, this provides escape capacity for 560 occupants.

Additional escape routes are also available into the Laboratory area, but these are not considered when assessing the escape capacity as Laboratory could represent high fire risk and it is preferred to direct occupants to the exits leading to outside.

2.7.4 Storage

It is understood that the Storage area would not be separated from the Laboratory area and any occupants will be able to freely move between the spaces. Therefore, the Storage area would largely evacuate via the Laboratory area.

However, an additional 1300mm wide exit is provided from the Storage area that will provide additional escape route in the event of escape into the Laboratory area being obstructed. This will provide sufficient escape capacity for the minimal number of occupants expected in the Storage area.

2.8 External Stairs

The First Floor area of the Office space is served by two 1500mm wide external stairs. This would provide sufficient escape capacity, as the number of people able to evacuate via the stairs will be limited by the 1200mm exits leading to the stairs.

The external staircases would require additional provisions to be suitable for evacuation, as follows:

- The doors leading into the external staircases will be fire resistant and provided with self-closers;
- Any part of the external walls within 1800mm of (an 9m vertically below) the flights and landings of the stairs will be fire resisting;
- Any part of the building elevation, including doors, within 1800mm of the escape route from the stair to a place of ultimate safety will be provided with fire resisting construction up to 1100mm above the route floor level.

As the external stairs are less than 6m in the vertical extent, no weather protection is required, with the exception of protection being provided to the top landings of the stairs where the disabled refuges are located.

01 Fire

2 Means of Escape

2.9 Plant Area

A Plant/MEWP storage area is provided to the East of the Laboratory area that will be fire separated from the rest of the building.

The MEWP storage area is located on Ground Floor only and is accessed via the protected stair serving the Plant areas above. The single direction travel distances in MEWP storage area exceed the recommendations of BS 9999 guidance at 19m before fit out. As such, an additional exit directly to outside will be provided to reduce this to within the recommendations of the code guidance.

The Plant areas are located over 3 floors. The Ground Floor plant area accessed either via the protected stair serving the levels above or via the Vehicle Access zone. This is considered suitable for the plant occupancy. The First Floor plant areas are separated from each other and are each accessed via a protected stair. The Second Floor plant area is an open air plant area.

The travel distances in all of the plant areas are within the recommendations of BS 9999. However, care should be taken that these distances in a single direction in First Floor plant areas are not increased above 18m after fit out. The travel distances are shown in Figure 2—4.



Figure 2—4 Travel Distances in the Plant Areas

01 Fire

2 Means of Escape

2.10 Roof

The escape from the roof area is available via the Plant area and a CAT ladder located in the Northwest corner of the building. This is considered suitable, as the roof will only be accessed occasionally by trained personnel.

The travel distances are within the 60m recommendation for open air plant areas where the escape is available in more than one direction (as per Annex F of BS 9999).

2.11 Airplane Fuselage

It is currently proposed to provide an airplane fuselage to the South of the building. This would be used for experiments and would be accessed via the temporary access set ups from the Storage area.

As the access and exit provisions from the fuselage are not known at the time of writing of this report, this was not reviewed. However, this would need to be reviewed in detail as design develops further at the later stages of the project to ensure that test participants can safely

2.12 Inner Rooms

A room from which the only escape route is through another room is called an inner room.

These should be avoided if possible, however if present, one of the following should be provided:

- The enclosures (walls or partitions) of the inner room should be stopped at least 500mm below the ceiling; or
- A suitably sited vision panel not less than 0.1m² should be located in the door or walls of the inner room to enable the occupants of the inner room to see if a fire has started in the outer room; or
- The access room should be fitted with a suitable automatic fire detection and alarm system to warn the occupants of a fire in the access room, to a sound pressure level in accordance with the minimum recommended in BS 5839-1:2013, or gives an immediate visual alarm conforming to BS EN 54-23 in the inner room if ambient noise levels are so great as to make alarm inaudible.

The Prep Booth and Server/Plant Room areas in the Ground Floor office area are currently designed as inner rooms. Therefore, this would need to be supported via one of the provisions discussed above.

01 Fire

3 Means of Escape for Disabled Persons

3.1 Introduction

Where access is provided for disabled people, provisions for means of escape must be provided. In any escape, it is important to have choice; this is equally true for disabled people and there are a range of options available. The preferred option for evacuation is horizontally to outside the building, another fire compartment or by fire evacuation lift. If these are not available or not in operation, then it may be necessary to carry a person with mobility impairment down the escape stair.

The minimum recommendations contained within current design codes are the provision of refuges. Building Regulations, BS9999:2017 and recent changes to fire safety legislation (covered by the Regulatory Reform (Fire Safety) Order 2005) contain recommendations that evacuation of disabled persons be designed into the management plan of the building. In order for this to be achieved, it is necessary to understand the capabilities or limitations of the building. It is noted that it is the building owner/ tenant's responsibility and not that of the fire service to assist people from the building.

A management strategy will need to be developed by the occupier, (as employers of individuals in the building), which will include Personal Emergency Evacuation Plans (PEEPs) to enable a flexible response to different situations.

3.2 Refuges

A refuge is a location where people whose abilities or impairments might cause their evacuation to be delayed can, if necessary, await assistance from a member of staff with the next part of their movement to a place of ultimate safety. This movement may be vertical (up or down stairs or via lifts), horizontal or a combination.

A refuge should be a place of relative safety. It should be protected from a fire for a period of time sufficient to enable the evacuation sequence to be completed without placing the person(s) needing assistance, or those rendering that assistance, at unacceptable risk from a fire within the premises.

It is also essential that the location of refuges and of wheelchair spaces within refuges does not have an adverse effect on the means of escape provided within the building.

A refuge should be of sufficient size both to accommodate a wheelchair and to allow the user to manoeuvre into the wheelchair space without undue difficulty. To accommodate the wide variety of wheelchairs in use, including powered wheelchairs, the space provided for a wheelchair in a refuge should not be less than 900mm x 1400mm allowing for manoeuvring. To enable wheelchair users to manoeuvre themselves into the refuge, the door width should have a clear opening of not less than 850mm.

It is proposed to locate refuges externally on the top landings of the external stairs serving the First Floor Office areas. This is considered reasonable based on the elevation being protected up to within 1800mm of the staircase, providing protection to the refuge. The refuges would also be located externally to the building and would not be affected by smoke. The top flight of the external stairs would also be provided with weather protection to ensure that occupants waiting at the refuge would not be subjected to adverse weather conditions.

3.3 Communication Systems

Where people may have to wait at a refuge location, a fire protected two-way communication system to a control point will be provided in accordance with BS 5839 Part 9. This system will alert the building management/ control point to enable rapid and unambiguous identification of those locations where people requiring assistance with evacuation might be waiting and relay this information to the person operating the evacuation lift. This system may also be used to reassure those waiting that assistance is on its way.

3.4 Use of Passenger Lift for Step Free Escape

There is no firefighting lift proposed on the premises. However, managed use of the passenger lift within the Office area to assist with evacuation of disabled persons unable to utilise the stairs for

escape was agreed with UCL fire officer in principle. This will be developed in more detail as design develops.

01 Fire

4 Active Fire Safety Systems

4.1 Fire Suppression

As the building is classified as potentially containing fire load resulting in ultra-fast fire growth of fire and contains high-rack storage, sprinklers will be provided to support this. These will need to be provided in Storage, Laboratory and Office areas. The sprinklers will be designed in accordance with BS EN 12845.

On the basis of providing maximum flexibility in types of storage (within reason) the sprinklers would be provided in a High Hazard Storage Category IV (HHS4) arrangement with an area of operation of 260m².

For a rack storage height of 8m, in-rack sprinklers would normally be required in addition to the ceiling sprinklers. However, the use of in-rack sprinklers is not suitable due to the requirement of the storage racks being removable for some of the proposed experiments. As such, Early Suppression Fast Response (ESFR) sprinklers will be provided.

ESFR sprinklers have a much higher "K-factor" and subsequent flow rate than standard sprinklers. A rough estimate for the proposed arrangement would be to use K25 sprinklers – allowing 12 of these to activate for a duration of 60 to 90 minutes would result in a water storage volume in the region of 570 – 850 cubic metres. All the above information is on the basis of following the LPC Sprinkler Rules.

These volumes of water will need to be further refined as the design develops in the next design stages, and will require specialist sprinkler protection suppliers input.

4.2 Automatic Fire Detection and Alarm

An automatic fire detection and alarm system should be provided in the building to at least an L2 standard designed in accordance with BS5839-1. The system will operate on single knock basis. Manual call points will also be provided in the Plant and Plant/MEWP Storage areas.

It is noted that cold smoke evacuation experiments are to be conducted in the area. These will necessitate the switching off of the detection and alarm system. As such, FRA would need to be conducted and management procedures would need to be developed and implemented based on the staff assistance with the escape of the occupants by the UCL to support this.

The exact design of the detection and alarm system and its type will need to be agreed upon at the next design stage.

4.3 Fire and Smoke Dampers

Ductwork which penetrates separate compartments either horizontally or vertically are to be provided with fusible link fire dampers (fire performance to be as per the compartment line crossed). Where ductwork enters protected corridors leading from stairs to external,

motorised fire/smoke dampers will be provided and activated by smoke detection.

The above should be designed in accordance with BS 9999 and BS EN12101-7 .

4.4 Smoke Venting

There is no requirement to provide smoke venting in the UCL PEARL building for fire safety purposes.

However, it is understood that the cold smoke clearance system will be provided in the building to support the evacuation experiments. This will not form part of the fire strategy and will not be suitable to use in the fire situation.

4.5 Emergency Lighting

Emergency lighting should be designed in accordance with BS 5266-1. This system includes an emergency escape route lighting system, an open area (anti-panic) lighting system, and an emergency lighting for high risk task area lighting system.

4.6 Escape Signage

Escape routes shall be marked with suitable exit signage. An exit sign will mark every doorway or other exit providing access to a means of escape. The position of such signs will be agreed between the architect and the fire service and will then be reviewed as part of the RRO fire risk assessment.

Exit & safety signs will comply with BS- EN – ISO 7010:2012 and BS ISO 3864-1:2011

4.7 Power Supply

Secondary and life-safety power supplies should be designed in accordance with BS 8519 . A secondary power supply will be provided to all life safety systems. The back-up power supply should be provided via diverse routes and the routes of supply fire separated from each other.

4.8 Arc-fault Protection

Where PV panels are to be installed, care should be taken that they are installed correctly and in accordance with the manufacturer's recommendations. During the early stages of this technology, there were a number of instances where poorly fitted panels led to a risk of fire and undue spread. It is therefore recommended that arc-fault protected is provided to these panels in order to mitigate the risk of ignition and therefore reduce the associated fire risk.

It is recommended that these panels also be fitted with a shutdown mechanism such that the fire brigade can shut down the panels to ensure no further power is generated. It is recommended that this be linked to the fire alarm system such that this shuts down automatically in the event

01 Fire

4 Active Fire Safety Systems

of a genuine fire alarm activation. This will help to ensure firefighter safety by removing power/electricity for potential fire loads.

01 Fire

5 Internal Fire Spread

5.1 Structural Fire Protection

The structure of the main space is to be constructed as a portal frame, which only supports the roof used for the provision of plant. Therefore, there is generally no requirement to fire protect it. The frame however should be fire protected where it forms part of a compartment wall, such as between the Plant areas and the rest of the building. Additionally, it should be protected where the fire resistance is required to the external wall to restrict the external fire spread of fire between the buildings.

As the building is fitted with a sprinkler system, the recommendations in the SCI publication P313 for designing the foundations to resist overturning need not be applied.

The structure of the internal office area should achieve 60 minutes fire resistance (R-Loadbearing). It is currently proposed to use CLT for the construction of the office area. Achieving the required fire resistance may involve treatment of the CLT, fire resisting boarding or utilising Eurocode charring rates to determine the structural fire performance. This should be completed by the specialist CLT contractors.

5.2 Compartmentation

There is no compartmentation proposed internally to the building in Laboratory, Storage or Office areas.

The Plant area will be separated from the rest of the building by 60 minutes fire resisting compartment wall (both integrity and insulation). Fire shutter will be provided across the entrance to Vehicle Access Zone.

5.3 Internal Linings

The internal linings for all walls and ceiling surfaces will achieve the following:

Table 5—1 Internal Fire Spread (Linings)

Location	National Class	European Class
Circulation/escape routes including staircases	0	B-s3, d2
Rooms (excluding small rooms)	1	C-s3, d2
Rooms less than 30m ²	3	D-s3, d2

Note:

- The National classifications do not automatically equate with the equivalent classifications in the European column, therefore, products cannot typically assume European class, unless they have been tested accordingly,
- When a classification includes “s3, d2”, this means that there is no limit set for smoke production and/or

flaming droplets/particles.

Parts of walls in a room may be of poorer performance than specified in Table 5—1 above, but not less than Class 3 or D-s3, d2. This variation is limited to a total area not exceeding one half of the room’s floor area, subject to a maximum of 20 m² in bedrooms and 60 m² elsewhere.

The following are excluded from the performance requirements of surface spread of flame:

- Doors and door frames;
- Window frames into which glazing is fitted;
- Architraves, cover moulds, picture rails and similar narrow small members; and,
- Fitted furniture, i.e. demountable sanitary “back panels”.

The provisions do not apply to the upper surfaces of staircases (i.e. treads and risers) because they are not significantly involved in a fire until it is well developed.

Where a room is an access room, although it provides circulation to other rooms it is in accordance with the recommendations for inner rooms and therefore the surface spread of flame used will be that applicable to the size of room.

5.4 Fire Stopping

Fire stopping should be provided on the line of compartment walls where gaps exist that could allow smoke and flames to breach the compartment wall. Joints between elements that serve as a barrier to the passage of fire should be fire stopped and all openings for pipes, ducts, conduits or cables to pass through any part of an element that serves as a barrier to the passage of fire should be:

- Kept as few as possible
- Kept as small as practicable
- Fire stopped (which in the case of a flue or duct should allow thermal movement),.

5.5 MEWP Storage

The impact of storage of battery powered heavy duty equipment on the premises is to be explored further in the next stage of the design development when the extent of storage provisions is better defined.

01 Fire

6 External Fire Spread

6.1 Building Separation and Maximum Unprotected Area

The risk of fire spread between buildings will need to be assessed and suitable measures taken to mitigate this. Where necessary, the use of alternative solutions and analysis tools can be investigated in order to limit the amount of fire rated glazing and external façade required.

The assessment was carried out in accordance with BR187. Please note that the boundary distances were taken to site boundary and did not account for the plane fuselage to the South of the building, as it was considered to be a part of the building premises. Calculations are provided in Appendix A.

The amount of unprotected elevations would need to be limited to the following:

- North elevation – 17% (239m²)
- South elevation – 20% (272m²)
- West elevation – 81% (464m²)

Any fire protected elevation (or part of the elevation) should achieve a fire resistance period of 60 minutes (when exposed from both sides if separation distance is less than 1m). The insulation criterion can also be reduced to 15 minutes where the elevation is located at 1m away from the notional boundary.

The East elevation is a part of the plant room that is fire separated from the rest of the building and has open air level at Third Floor. The requirement for fire protecting the elevations of the plant rooms will be explored in more detail at the next stage of the design development when the contents of the area are defined in more detail.

6.2 External Faces of the Building

6.2.1 Code Guidance

As the building does not house sleeping accommodation and is less than 18m high, there is not Building Regulations restrictions on the insulation used in the external façade build up.

It is however noted that in the updated UCL Fire Safety Requirements (issued on 11/04/2019), there is a requirement for all external cladding systems and all elements of the cladding system (including render materials, insulation materials and any rain-screen cladding, but not including elements such as gaskets, sealants and similar) to be non-combustible (or, as a minimum, materials of limited combustibility) and achieve European classification of Class A1 and A2 regardless of height and being non-sleeping accommodation.

The external wall surfaces should meet the provisions of Figure 47 of BS9999, as shown below.

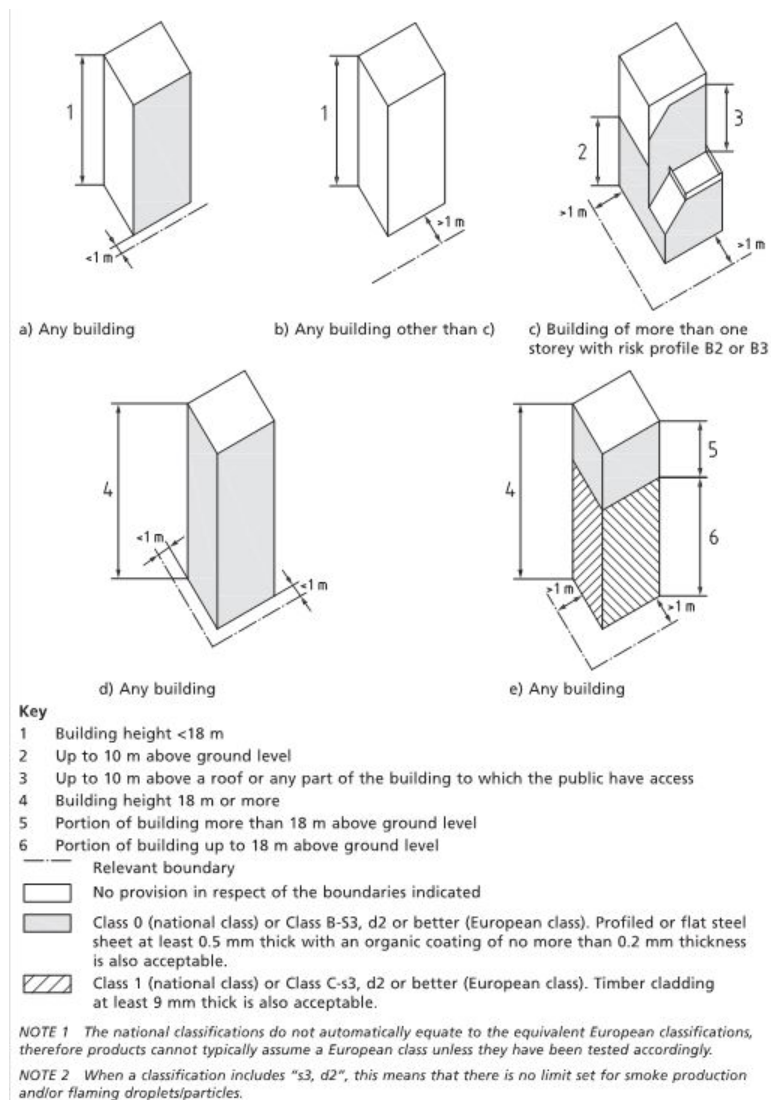

Figure 6-1 Figure 47 of BS 9999 – Provisions for external surfaces of walls

01 Fire

6 External Fire Spread

It is also recommended that any external storage should be located away from the building, i.e. approximately at least 5m-6m away as a rule of thumb.

6.2.2 Cavity Barriers

Cavity barriers should be provided to close the edge of cavities including around openings. Cavity barriers should also be provided:

- At the junction between an external cavity wall (except where the cavity wall conforms to Figure 36 of BS 9999) and every compartment floor and compartment wall, and
- At the junction between an internal cavity wall (except where the cavity wall conforms to Figure 36 of BS 9999) and every compartment floor, compartment wall, or other wall or door assembly which forms a fire resisting barrier. Provision of cavity barriers is shown in Figure 35 of BS 9999.

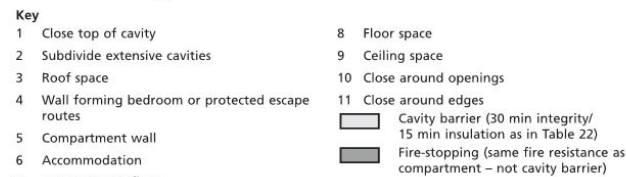
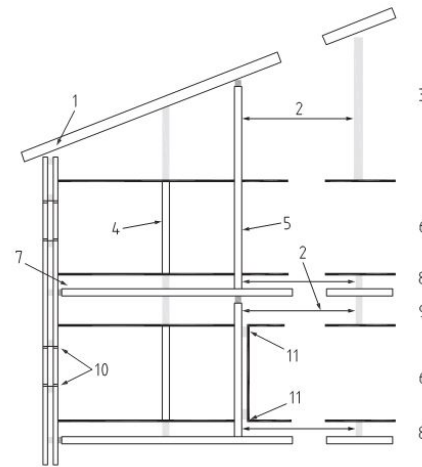
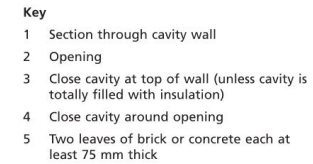
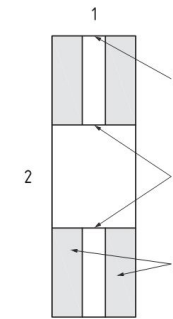

Figure 6-2 Figure 35 of BS 9999 – Provisions for cavity barriers



NOTE 1 Cavities may be closed with a material that might not meet the various recommendations in Table 22 for cavity barriers. The purpose of closing the cavity is to restrict airflow within the cavity.

NOTE 2 Cupboards for switch boards, service boxes, service panels, etc. may be installed provided that:

- there are no more than two cupboards per compartment;
- the openings in the outer wall leaf are not more than 800 mm x 500 mm for each cupboard; and
- the inner leaf is not penetrated except by a sleeve not more than 80 mm x 80 mm, which is fire-stopped.

NOTE 3 Combustible materials may be placed within the cavity.

Figure 6-3 Figure 36 of BS 9999 – Cavity wall excluded from provisions for cavity barriers

01 Fire

6 External Fire Spread

6.2.3 Extensive Cavities

The maximum dimensions of cavities should be limited to 20m in any direction where the surface spread of flame classification of the exposed products is Class 0 or Class 1 (national class) or Class A1 or A2-s3, d2 or B-s3,d2 or Class C-s3, d2. If none of the above classifications can be confirmed the maximum dimension should not exceed 10m in any direction.

6.3 Roof Coverings

For restriction of fire spread over roofs the properties of a roof covering are in relevance if:

1. If the roof is close enough to a boundary to be a risk of ignition from a fire in other buildings; and
2. In the vicinity of a compartment wall, to avoid fire spread between compartments via a roof covering.

The separation distances for roof coverings are given in table 6—1:

Table 6—1 Limitation on Roof Coverings

Designation of covering of roof or part of roof	Distance of roof from any point on relevant boundary			
	Less than 6m	At least 6m	At least 12m	At least 20m
AA, AB or AC	Acceptable	Acceptable	Acceptable	Acceptable
BA, BB or BC	Not acceptable	Acceptable	Acceptable	Acceptable
CA, CB or CC	Not acceptable	Not acceptable	Not acceptable	Acceptable
AD, BD	Not acceptable	Not acceptable	Acceptable	Acceptable
DA, DB, DC	Not acceptable	Not acceptable	Not acceptable	Not acceptable

Note 1: The performance of roof coverings is designated by reference to the test methods given in BS 476-3 (National Class) and BS EN 13501-5 (European Class)

Where PV panels are to be provided, care should be taken when installing significant numbers of panels, such that these do not attribute to undue fire spread. As a minimum, the performance of the PV panels should achieve the same classification as the roof coverings applicable to that area to inhibit effectively the rapid spread of fire over the roof coverings.

01 Fire

7 Access and Facilities for the Fire Service

7.1 Fire Service Access

There is no requirement to provide firefighting shafts in the building. The firefighting access could be provided from the perimeter of the building. This would require fire vehicle access to be provided to 15% of the building perimeter.

Note, any perimeter wall (elevation) to which vehicle access has been provided should have a door which is at least 750mm wide.

7.2 Fire Vehicle Route Specification

The vehicle access route should be designed in line with the Table 7—1 below.

The fire vehicles should not have to drive more than 20m in a dead end situation or turning facilities would need to be provided.

7.3 Fire Hydrants

For buildings not provided with fire mains or where the building is fitted with a wet fire main, hydrants should be provided within 90 m of an entry point to the building and not more than 90 m apart. All hydrants should have signage in accordance with BS 3251 and should not be located within 6 m of any building.

Table 7—1 Fire Service Access Route Specification

Appliance Type	Min. Width of Road between Kerbs (m)	Min. Width of Gateways (m)	Min. Turning Circle between Kerbs (m)	Min. Turning Circle between Walls (m)	Min. Clearance Height (m)	Min. Carrying Capacity (tonnes)
Pump	3.7	3.1	16.8	19.2	3.7	14.0
High Reach	3.7	3.1	26.0	29.0	3.7	23.0

01 Fire

8 Fire Safety Management

A significant part of the fire safety regimes within any building is the standard and quality of fire safety management put in place to ensure that the 'built provision' is maintained to appropriate standard and that people who occupy that building understand their roles and responsibilities as part of the fire safety plan.

This report is not the fire safety management policy and procedures document for the proposed works but the 'collective proposal' for passive and active measures, which support the responsible person's statutory compliance with the Regulatory Reform (Fire Safety) Order 2005. In determining these measures, we have made certain assumptions on the quality of fire safety management that will be put in place.

We have assumed that it is the intention to apply and maintain, as a minimum, the standards necessary to meet statutory requirements while seeking to achieve best management practice in accordance with Fire Safety Legislation and good practice standards. The responsible person's intention is, as far as is reasonably practicable, and in accordance with legal obligations and standards, to:

- Provide and maintain passive and active fire prevention, protection measures according to the purpose or use of the building.
- Provide comprehensible and relevant information to employees, students and others, through the provision and availability of emergency instructions or fire safety plans and the risks identified by relevant risk assessments.
- Provide a programme of Fire Safety Training.
- Carry out and keep under review a Fire Risk Assessment, which analyses building and process fire risks, the existing preventative and protective measures and identifies areas for improvement.
- Ensure suitable and sufficient evacuation procedures are in place in the premises.
- Ensure that persons appointed to positions of fire safety responsibility are competent to undertake those duties.
- Where appropriate, to prepare and keep under review risk assessments in relation to the use, storage, handling, disposal, transportation of substances and ensure that, so far as is reasonably practicable, the risks are reduced or controlled.

As part of the Fire Safety Management Plan, existing emergency evacuation procedures and plans will be reviewed to determine how they will apply to this building, and as required, and will consider:

- Effectiveness of the alarm;
- Awareness of team members to the situation;
- Handling of the public, or people who are less familiar with the building;
- Effectiveness of evacuation to cover all people;
- Procedures undertaken for checking the building or part of the building affected;
- Effectiveness of disability evacuation procedures;
- Speed of evacuation;
- Use of fire escape routes;
- Ease of access to assembly point; and,
- Procedures for briefing the Fire Brigade on arrival.

The passive and active measures proposed do not attach any additional or onerous fire safety management provisions on to the building in excess of those reasonably expected in this type of premises.

01 Fire

Appendix A External Fire Spread Calculations

BURO HAPPOLD ENGINEERING	Project	UCL PEARL	Sheet No	1
	Area of Project	External Fire Spread	Revision	A
	Elevation Description	North Elevation	Prepared by	AT
			Checked by	JLM

Design Assumptions

- In accordance to BR187 - 2014 using the Enclosing Rectangle Method
- If sprinklers are taken into account, unprotected area or boundary distance is doubled,

Calculate allowable boundary distance
 Calculate allowable unprotected area

Input

Building purpose <i>for Shop and commercial, Industrial, Storage or Other non-residential purposes enter 1</i> <i>for Residential, Office or Assembly and recreational purposes enter 2</i>	1
Is building sprinklered? <i>Enter Y if yes and N if No</i>	Y
Height of enclosing rectangle	13.7 (m)
Width of enclosing rectangle	100.5 (m)
Distance to the boundary	3 (m)

Allowable percentage and area of façade unprotected

Tables Method	17%	239 (m ²)
Calculation Method	13%	181 (m ²)

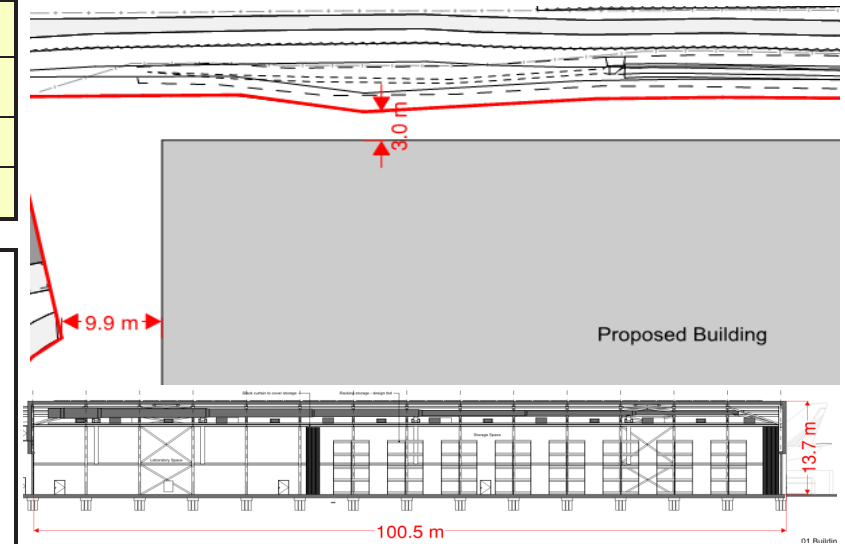

01 Fire

Appendix A External Fire Spread Calculations

BURO HAPPOLD ENGINEERING	Project	UCL PEARL	Sheet No	1
	Area of Project	External Fire Spread	Revision	A
	Elevation Description	South Elevation	Prepared by	AT
			Checked by	JLM

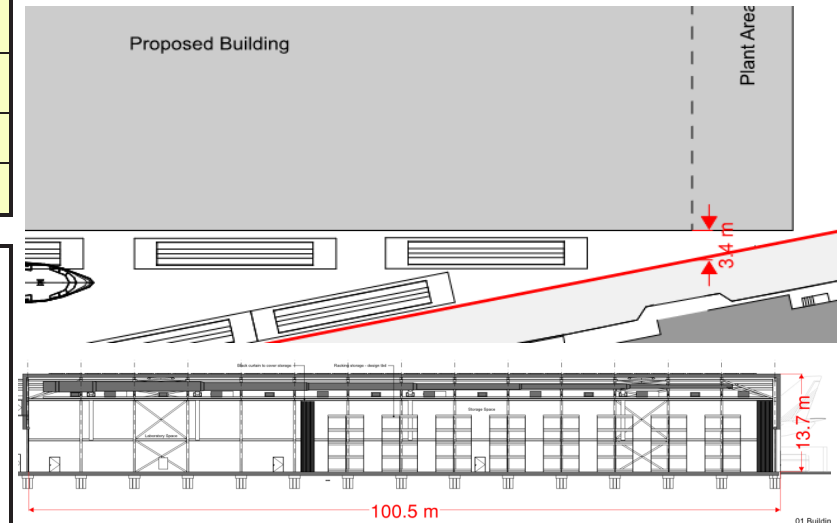

Design Assumptions

- In accordance to BR187 - 2014 using the Enclosing Rectangle Method
- If sprinklers are taken into account, unprotected area or boundary distance is doubled,

- Calculate allowable boundary distance
 Calculate allowable unprotected area

Input

Building purpose <i>for Shop and commercial, Industrial, Storage or Other non-residential purposes enter 1</i> <i>for Residential, Office or Assembly and recreational purposes enter 2</i>	1
Is building sprinklered? <i>Enter Y if yes and N if No</i>	Y
Height of enclosing rectangle	13.7 (m)
Width of enclosing rectangle	100.5 (m)
Distance to the boundary	3.4 (m)

Allowable percentage and area of façade unprotected

Tables Method	20%	272 (m ²)
Calculation Method	15%	205 (m ²)

01 Fire

Appendix A External Fire Spread Calculations

BURO HAPPOLD ENGINEERING	Project	UCL PEARL	Sheet No	1
	Area of Project	External Fire Spread	Revision	A
	Elevation Description	West Elevation	Prepared by	AT
			Checked by	JLM

Design Assumptions

- In accordance to BR187 - 2014 using the Enclosing Rectangle Method
- If sprinklers are taken into account, unprotected area or boundary distance is doubled,

- Calculate allowable boundary distance
- Calculate allowable unprotected area

Input	
Building purpose <i>for Shop and commercial, Industrial, Storage or Other non-residential purposes enter 1</i> <i>for Residential, Office or Assembly and recreational purposes enter 2</i>	1
Is building sprinklered? <i>Enter Y if yes and N if No</i>	Y
Height of enclosing rectangle	13.7 (m)
Width of enclosing rectangle	42 (m)
Distance to the boundary	9.9 (m)

Allowable percentage and area of façade unprotected		
Tables Method	81%	464 (m ²)
Calculation Method	77%	441 (m ²)

